

产品质量证明书

Product Quality Certificate

产品： 氢燃料电池堆（1500W） Product: Hydrogen Fuel Cell Stack (1500W)		产品序列号 Serial Number	SZFC-1500
主要技术指标 Main technical indicators			
检验标准 Quality Inspection Standard		实测结果 Test Results	
输出性能 Output Performance	功率 Power	1500W	
	操作电压 Operating Voltage	40V-74V	
	操作电流 Operating Current	0A-37.2A	
	效率 Efficiency	>40%	
燃料 Fuel	氢气纯度 Hydrogen Purity	≥99.99% (CO<1PPM)	
	氢气压力 Hydrogen Pressure	0.035Mpa~0.05Mpa	
	氢气耗量 Hydrogen Consumption	(37.2A) 23L/min	
工作环境 Working Environment	环境温度 Ambient Temperature	0-35°C	
	环境湿度 Ambient Humidity	10%-90%	
	储存环境 Storage Environment	0-60°C	
物理参数 Physical Parameter	片数 Number of Cells	80	
	电堆尺寸 Stack Dimensions	145*162*308mm	
	重量 Weight	5207g	

1500W氢燃料电池堆使用说明书

1500W Hydrogen Fuel Cell Stack User's Manual

1. 管路连接：将氢气连接→减压阀→连接燃料电池电堆氢气进气管。进气管连接进气阀后接入燃料电池进气口（IN），排气口（OUT）一端连接 排气阀。（燃料电池不使用时将进气口密封保存。）

Pipeline Connection:

Connect the hydrogen gas →the pressure reducing valve → connect to the hydrogen intake pipe of the fuel cell stack. The intake pipe is connected to the intake valve and then enters the fuel cell's intake port (IN), and one end of the exhaust port (OUT) is connected to the exhaust valve.

(When the fuel cell is not in use, seal the intake and exhaust ports for storage.)

2. 启动:

- (1) 逐步调节氢气减压阀，调到 0.05MPa。
- (2) 控制盒外接 13V 电源。
- (3) 按下控制盒 ON/OFF 按钮，控制正常运行。
- (4) 氢气进入燃料电池堆，燃料电池开始工作，风扇开始转动。

Startup:

- (1) Gradually adjust the hydrogen pressure reducing valve to 0.05MPa.
- (2) Connect the control box to a 13V power supply.
- (3) Press the ON/OFF button on the control box to initiate normal operation.
- (4) Hydrogen enters the fuel cell stack, the fuel cell starts operating, and the fan begins to rotate.

3. 燃料电池启动后，可以根据需要在额定功率范围内用恒流方式，以 3A 斜率逐步增加负载，设置电流值分别为：3A、6A、9A、12A、……、31A，加载斜率 3A/10S，建议最大电流值设定不超过 37.2A。

After the fuel cell starts, it can gradually increase the load with a 3A slope in a constant current mode within the rated power range according to needs, and set the current values as follows: 3A, 6A, 9A, 12A,..... , 31A, the loading slope 3A/10S, the maximum current value is recommended not to exceed 37.2A.

4. 燃料电池在不同运行电流下，输出功率不同，参考尾页放电曲线图。

At different operating currents, the fuel cell outputs different power levels. Refer to the discharge curve chart on the last page.

5. 关闭氢燃料电池:

准备关闭燃料电池时，关闭负载（关闭负载有条件的情况下，以 5A 斜率逐步缩小电流值，如当前电流设定为 31A，设定 26A、21A、……、5A、0A，每个电流值下维持 5S 左右，起到保护燃料电池寿命作用），关闭氢气 阀门，按下控制盒 ON/OFF 按钮，关闭控制盒外接电源，风扇会全速转动，直至燃料电池中的氢气耗完

Shutting down the hydrogen fuel cell:

When preparing to shut down the fuel cell, turn off the load. If turning off the load is conditional, gradually reduce the current value with a slope of 5A. For example, if the current setting is 31A, set 26A, 21A, ..., 5A, 0A. Maintain each current value for about 5 seconds, serving to protect the fuel cell's lifespan. Close the hydrogen valve, press the ON/OFF button on the control box, turn off the external power supply to the control box, and the fan will run at full speed until the hydrogen in the fuel cell is depleted.

6. 控制保护:

控制盒指示灯绿灯常亮，燃料电池正常工作，指示灯绿灯闪烁，电池运行故障。氢燃料电池运行电压不要低于 40V，电压低于 40V 控制板会保护电堆降载直至停止工作。

Control and Protection:

The green light on the control box remains steady when the fuel cell is operating normally. If the green light flashes, there is a battery operation fault. The operating voltage of the hydrogen fuel cell should not be lower than 40V. If the voltage drops below 40V, the control board will initiate protection, and the cell will unload until it stops working.

注意事项 Precautions

1. 燃料电池运转时，一定要确保燃料电池中氢气的压力在 0.05MPa，同时一定要确保足够的氢气流量。如果供氢系统中，氢气压力太高、太低或者流量不足都会对燃料电池造成损害。

When the fuel cell is in operation, it is essential to ensure that the hydrogen pressure in the fuel cell is at 0.05MPa, as well as sufficient hydrogen flow. Damages to the fuel cell can occur due to a much higher, lower hydrogen pressure or insufficient supply in the hydrogen supply system.

2. 氢燃料电池电堆氢气进口确保在上，电堆排气口向下，保持排水流畅（否则会损坏电池）。

Please keep the hydrogen intake of the hydrogen fuel cell stack upward and the exhaust port of the stack downward to ensure smooth drainage (otherwise, the cell will be damaged).

3. 一定要先启动燃料电池，然后加负载。

Be sure to start the fuel cell first and then add the load.

4. 电池所在运行环境温度不能过高，过高会影响电堆输出性能，或者高温控制盒会保护。

In the operating environment, the temperature surrounding the stack should not be excessively high, as excessive heat can adversely affect the performance of the cell stack. Alternatively, the high-temperature control box will activate to provide protection.

5. 使用完毕后最好使用自封袋进行保存。

It is recommended to use a self-sealing bag for storage after use.

申明与警示 Declaration and Warning

1. 在操作燃料电池电堆前请通读此说明书，并在操作过程中将本说明书放于手边。
Please read this manual carefully before operating the fuel cell stack, and keep this manual within reach during the operation.
2. 按照本说明书所列说明进行操作。
Operate according to the instructions listed in this manual.
3. 禁止对 1500W 燃料电池电堆进行拆解或改装。对该电堆的任何修改都会构成重大的安全隐患。智达盛世（广州）氢能与环境科技有限公司不对任何由于未经允许的改装所造成的损伤负责。
It is forbidden to disassemble or modify the 1500W fuel cell stack. Any modification to the stack will constitute a major safety hazard. SENZA Hydrogen Energy And Environmental Technology Co., Ltd. is not responsible for any damage caused by unauthorized modification.
4. 1500W 燃料电池电堆在运行过程中需消耗氧气。为防止缺氧，仅可在良好的通风环境中运行。
The 1500W fuel cell stack consumes oxygen during operation. A well- ventilated environment is required to prevent hypoxia during operation.
5. 由于氢气属无色、无嗅的可燃气体，因此严禁在 1500W 燃料电池电堆附近吸烟，并确保燃料电池电堆远离火源和热源。
Given that hydrogen is a colorless and odorless flammable gas, smoking is strictly prohibited near the 1500W fuel cell stack, and the fuel cell stack should be kept away from fire sources and heat sources.
6. 确保 1500W 燃料电池电堆远离儿童。
Ensure that the 1500W fuel cell stack is kept away from children.

1500W 氢燃料电池电堆

1500W Hydrogen Fuel Cell Stack

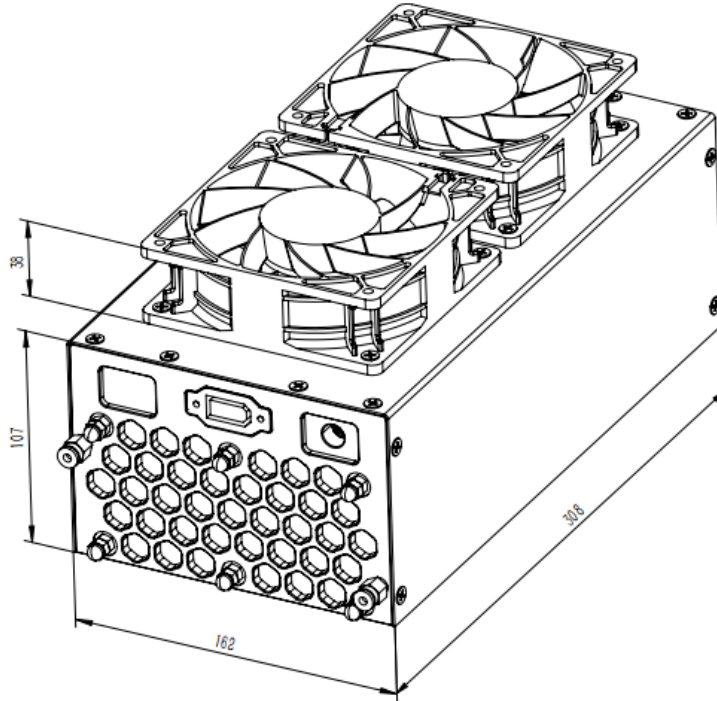

1500W Hydrogen Fuel Cell Discharge Curve

